

INNOVATION LEADS TO VALUE



# SWE 20F MINI EXCAVATOR

◆ Total weight: 1.94t

◆ Engine power: 13.4kW/2200rpm

◆ Bucket capacity: 0.04m<sup>3</sup>



- ◆ SWE20F is equipped with high-performance engine as well as brand pumps, valves and motors for leading configuration.
- ◆ Pilot full hydraulic control method is used for the fast and precise control of multiple elements at the same time, and automatic speed change function is provided for walking to meet the walking performance requirements under complex terrain conditions.
- ◆ With moving arm yaw, chassis expansion and contraction and other functions for excellent cooperative operation performance in small spaces. It is the true small space construction expert.
- ◆ Reinforced structure with integral cast deflection head for excellent appearance and more durable, reliable and safe structure.
- ◆ Closed and open cabins are available for clients. It has been FOPS and TOPS certified to ensure the safety of the driver.
- ◆ It is equipped with a spacious and comfortable operation space, a 5-inch LCD display, and suspension shock-absorbing seats that can improve ride comfort.
- ◆ With the flip-over seat structure, electrical parts can be serviced more conveniently. It is easy to maintain the power system by just opening the tail cover.



### Parameters and performance of the main machine

Dimension (L*W*H)	mm	3905x990x2235	
Overall weight	With rubber track	t	
	With steel track	t	
Standard bucket capacity	m <sup>3</sup>	0.04	
Bucket digging force	kN	22.7	
Arm digging force	kN	9.8	
Max. drawbar pull	kN	18.1	
Travel speed (Max/Min)	km/h	3.5/2	
Gradeability	%	57	
Ground pressure	kPa	30	
Slewing speed	rpm	10	
Engine	Brand	YANMAR	
	Model	3TNV80-SSU(EURO V)/ 3TNV80F-SSSU (US IV)	
	Max. torque	N.m/rpm	67.4/1600
	Displacement	L	1.267
	Power/Rotation speed	13.4/2200	
Fuel tank capacity	L	23	
Primary pump	Type	2 variable plunger pump, 1 gear pump, 1 pilot pump	
	Flow rate	L/min	2*21+13+6
Pressure of main relief valve	MPa	21/16	
Hydraulic oil tank capacity	L	35	

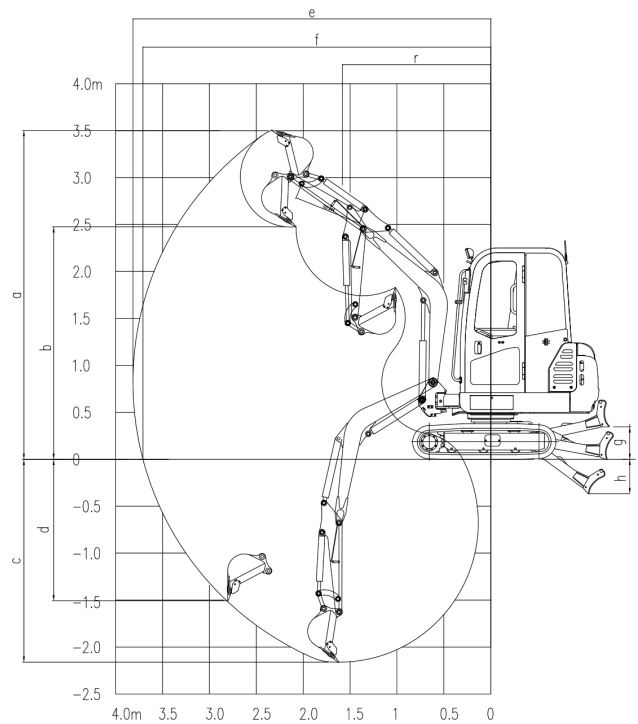

### Working range

	Boom length	mm	1800
	Arm length	mm	1150
a	Max. digging height	mm	3770
b	Max. dumping height	mm	2720
c	Max. digging depth	mm	2380
d	Max. vertical digging depth	mm	1870
e	Max. digging reach	mm	4040
f	Max. digging reach at ground level	mm	3945
g	Max. lift height of the dozer blade	mm	295
h	Max. digging depth of dozer blade	mm	360
r	Min. swing radius	mm	1580

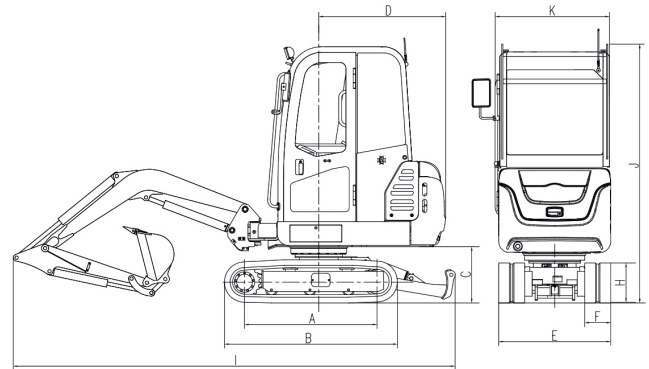

### Outline dimensions

A	Length to center of rollers	mm	1210	G	Chassis ground clearance	mm	160
B	Total track length	mm	1540	H	Track height	mm	352
C	Counterweight clearance	mm	460	I	Total length	mm	3905
D	Tail swing radius	mm	1120	J	Max. height of cab	mm	2235
E	Track width	mm	990/1360	K	Uppercarriage width	mm	990
F	Track shoe width	mm	230				

◆ The above parameters may be different due to product upgrading.

